

REFRIGERATOR MANUFACTURER
Turbo air
 more durable, efficient, beautiful

4184 E. Conant St.
 Long Beach, CA 90808
 Tel. 310-900-1000
 Fax. 310-900-1077
www.turboairinc.com

Project :
 Model # :
 Item # : Qty :
 Available W/H :
 Approval :

Glass Door Undercounter Ref.

Side Mount Undercounters
 J Series

Model : JUR-48-G-N



≡ FEATURES & BENEFITS ≡

- **Digital temperature control & monitor system**
 Keep food products safe by maintaining constant temperatures. External digital display allows for easy monitoring.
- **Hydrocarbon refrigerants (R-290)**
 With innovative and eco-friendly technology, Turbo Air brings you hydrocarbon refrigerators designed to meet DOE's Energy Conservation Standards in 2017 and to use EPA's SNAP Program approved HC refrigerants. Hydrocarbon refrigerants do not deplete the ozone layer and have very low contribution to global warming (ODP-0, GWP-3).
- **Side mount compressor unit**
 With compressors positioned on the side of the unit, our refrigerators can now be serviced without being moved. Our innovative, front breathing feature also allows this model to be highly efficient in narrow spaces.
- **Exterior & interior of the cabinet**
 The Turbo Air J series boasts a stainless steel exterior with glass doors & AL frame (galvanized steel back and bottom). Interior is stainless steel floor with AL sides and back. It guarantees the utmost in cleanliness and long product life. The J series adds a touch of style to the most refined setting.
- **Hot gas condensate system**
 Through Turbo Air's creative innovation, the condensate system surfaces have been specially treated to resist corrosion. This not only increases efficiency without the risk of refrigerant leakage from corrosion, but also thoroughly prevents the overflow of condensate water.
- **Adjustable, heavy duty, PE (polyethylene) coated wire shelves**
- **LED interior lighting & fan control**
 Energy efficient LED lighting lights every corner, making items easy to find. Fan control function automatically shuts off the fan when the door is open, which prevents hot air from being drawn in, thus maintaining the cool inner temperature.
- **High-density polyurethane insulation**
 The entire cabinet structure and solid doors are foamed-in-place using high density, CFC free polyurethane insulation.
- **Ergonomically designed doors**
 Customers' fatigue fades away with easy grip handles and doors that open effortlessly. These features along with self-closing doors make this the ultimate choice in customer convenience.
- **Magnetic door gaskets**
 Magnetic door gaskets are of one-piece construction, removable without tools for ease of cleaning and replacement.
- **Easy open front grille with condenser cleaning brush kit**
 Front grille cover is easily removable without any tools, which makes condenser cleaning easy and convenient at any time. Handy condenser cleaning brush is included inside the front grille cover.
- **Refrigerator holds 33°F ~ 39°F for the best in food preservation**

NATURAL Refrigerant

CEC
 ISO9001:2008

ETL
 Intertek

ETL
 Intertek

2 YEAR WARRANTY

Compressor 5 YEAR WARRANTY
 (U.S.A. only)

Model	Swing Doors	CU./FT.	#of Shelves	HP	AMPS	Crated Weight (lbs.)	L x D* x H† (inches)
JUR-48-G-N	2	10.66	2	1/4	2.3	244	47 1/4 x 27 1/2 x 28 3/4

Model : JUR-48-G-N

ELECTRICAL DATA	
Voltage	115/60/1
Plug Type	ⓘ NEMA 5-15P
Full Load Amperes	2.3
Compressor HP	1/4
Cord Length (ft.)	9.2
Refrigerant	R-290
DIMENSIONAL DATA	
Net Capacity (cu. ft.)	10.66
Ext. Length Overall (in.)	47 1/4 (1200mm)
Ext. Depth Overall (in.)*	27 1/2 (699mm)
Ext. Height Overall (in.)†	28 3/4 (730mm)
# of Doors	2
# of Shelves	2
Shelf Size (L x D) (in.)	15 1/2 x 20 1/4
Net Weight (lbs.)	184
Gross Weight (lbs.)	244

Design and specifications subject to change without notice.

Actual shipping weight may differ due to extra packing materials for product protection.

* Depth does not include 1" for rear spacers.

† Height does not include 5" for caster height.

■ **WARRANTY : 2 Year Parts and Labor Warranty**
Additional 3 Year Warranty on Compressor

■ **STANDARD FEATURES**

- Anti-corrosion coated evaporator
- Self-contained system
- Standard 4" dia. swivel casters with locks on the front set
- Door locks standard

■ **OPTIONAL ACCESSORIES**

- 1" caster, 1/2" diameter & 13 TPI: S28R813660 (non-brake)
- 2.5" caster, 1/2" diameter & 13 TPI: 30265H0100 (non-brake), 30265H0200 (w/ brake)
- 5" caster, 1/2" diameter & 13 TPI: M726500100 (non-brake), M726500200 (w/ brake)
- Leveling leg, 1/2" - 13 TPI x 1.54": LFM1213566
- 6" ABS plastic leg: 30221M0200
- 6" stainless steel leg: 30221M0600
- Additional PE coated wire shelf: KR29000100

PLAN VIEW

(unit : inch)

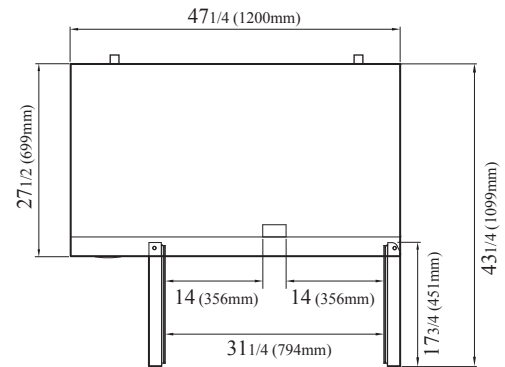

TOP VIEW

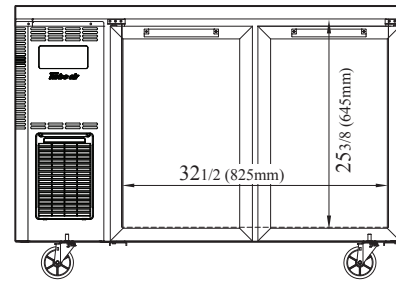

FRONT VIEW

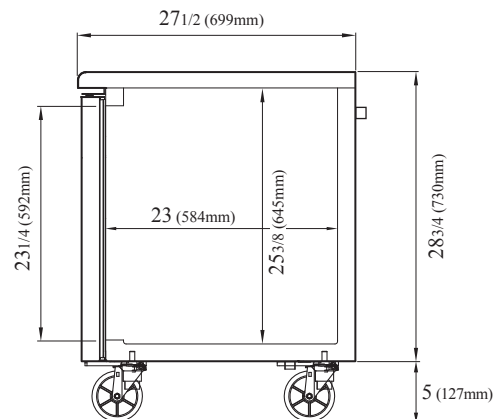

SIDE VIEW

Ver.20200415



- Turbo Air : 800-627-0032
- GK : 800-500-3519
- Warranty : 800-381-7770
- AC : 888-900-1002

